

30th ROBO-ONE
14th ROBO-ONE Light
1st ROBO-ONE auto
Competition Rules



Drafted Nov. 27, 2016 (changes from previous version in red)
Revised Dec.27.2016 ((changes from previous version in blue)



Drafted: Biped Robot Association
Inquires: bra-info@biped-robot.or.jp



Participation Flow for **30th ROBO-ONE / 14th ROBO-ONE Light / 1st ROBO-ONE auto**

The participation and attendance flow for the **30th ROBO-ONE / 14th ROBO-ONE Light / 1st ROBO-ONE auto** competition is as follows.

- 1) Publication of competition rules (3 months prior to the competition)
- 2) Participation applications received (from 1 month prior to the competition)
- 3) First day of the competition
 - Standards screening
 - ROBO-ONE Light/ **ROBO-ONE auto** Preliminaries
 - ROBO-ONE Light Finals Tournament
 - **ROBO-ONE auto Finals Tournament**
- 4) Second day of the competition
 - Standards screening
 - ROBO-ONE Preliminaries
 - ROBO-ONE Finals Tournament

1 Publication of competition rules

The competition rules are generally published on the official ROBO-ONE website (<http://www.robo-one.com>) three months prior to the competition.

2 Participation applications

Participation in ROBO-ONE/ROBO-ONE Light/**ROBO-ONE auto** is open to all. There are no nationality requirements. Participation applications are only taken on the official ROBO-ONE website (<http://www.robo-one.com>). You must register as a competitor and also register to participate. Complete the registration procedures by following the instructions on the screen. Applications are not screened, so when building your robot be sure to read the competition rules carefully to avoid rule infractions.

Team and robot names should be 20 letters or less.

Explanation 1

Robot and team names may continue to be registered in Japanese, but you must also enter English names. At international competitions, the English names (letters) are used.

3 Standards screening

In the standards screening, robots are screened for whether they have been created in accordance with the competition rules. The weight limits for this competition are **5 kg or less for ROBO-ONE auto** 3 kg or less for ROBO-ONE and 1 kg or less or a certified robot for



ROBO-ONE Light. The standards for certified robots are as followed.

Standards for certified robots

- (a) Commercially available robot certified by the Biped Robot Association.
- (b) Complies with the rules stipulated for each certified robot listed on the official ROBO-ONE website.
- (c) Does not use optional parts other than the certified optional parts listed on the official ROBO-ONE website.
- (d) If making modifications beyond what is stated in the user's manual, etc. for a commercially available robot that is provided by the manufacturer, the weight must not increase more than 20% and the length of the left and right arms must not increase more than 10 mm each. However, the weight must not exceed 2 kg.
Modifications may include adding color, adding stickers, adding head parts that do not enhance performance, decorating with paper, fabric, plastic or sponge materials, and changing the software. Adding decorative lights and sensors and changing the control microprocessor are also permitted.

If your robot fails the standards screening, you will not be able to participate in the competition, so make sure to sufficiently review the rules and standards in advance.

4 Preliminaries

ROBO-ONE will always perform preliminaries. ROBO-ONE Light and ROBO-ONE auto may not perform preliminaries depending on the number of participating robots.

In the preliminaries, the robots travel 4.5 meters (subject to change depending on the venue). If the robot goes off course or runs out of time, the distance to that point is recorded. Places are determined by the time to the goal or distance travelled, and the top 32 robots (not including the top 3 robots in the world rankings, robots certified at sanctioned tournaments and Hall of Fame entrants) move on to the finals tournament.

Past winners and competitors with byes are automatically in the finals, but they participate in the prelims for tournament seeding purposes.

5 Finals Tournament

All final tournaments will be done with 48 robots.

ROBO - ONE Light and ROBO - ONE auto's final tournament will be done with all robots when the number of participants are lower than 64.

Only one robot per operator may participate in the finals tournament.

The competition consists of one round of 3 minutes and an overtime of 2 minutes, depending on the circumstances. There may be multiple overtimes, so have batteries, etc. ready.

Depending on the situation, the game time may be set to 2 minutes per round.



ROBO-ONE Competition Rules

1 Preamble

The purpose of ROBO-ONE is to promote the fun and excitement of robots to more and more people. It aims to be a robot competition that is enjoyable for spectators and highly motivating for participants. For this reason it emphasizes technological prowess and entertainment value over winning and losing.

Technical information is also released to the extent possible to promote the spread and sound development of robotic technologies.

2 About the Competition

The competition involves matches in a preset ring between biped robots created by participants. Winners and losers are determined by the decision of referees and judges. The competition consists of a tournament-style main round and a preliminary round preceding it.

3 Ring Standards and Conditions

3.1 Ring

The size of the rings is shown in Diagram 1. There are cases where the game progresses simultaneously with two rings and the case where it progresses with one ring and the dimensions are as described respectively.

Surface bumps are $\pm 1\text{mm}$ or less. There are no particular specifications with regard to the material.

Do not place objects up to 2 m of the ring and 30 cm around the ring, down to 30cm to the floor around the ring. However, the referee can move this range freely. (See diagram 1-(3))

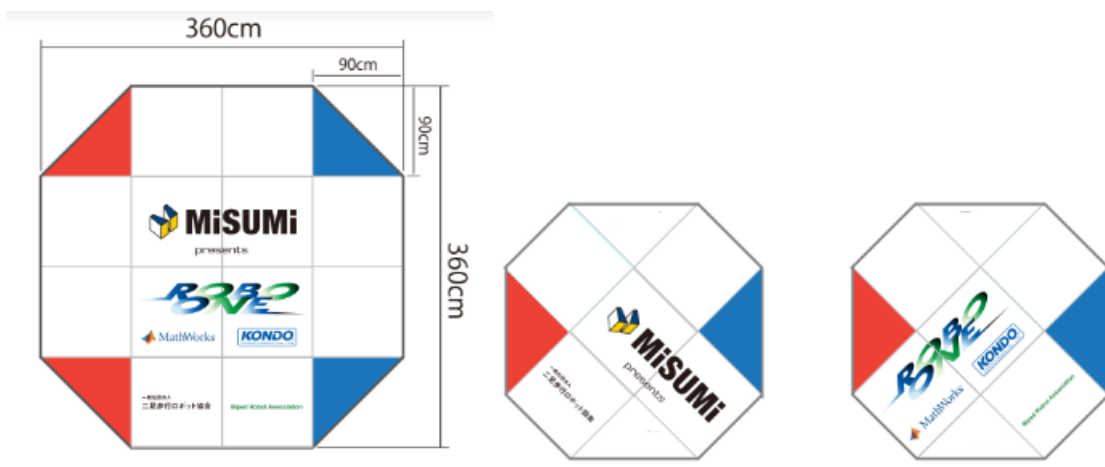

(1) With one rings

(2) With two ring

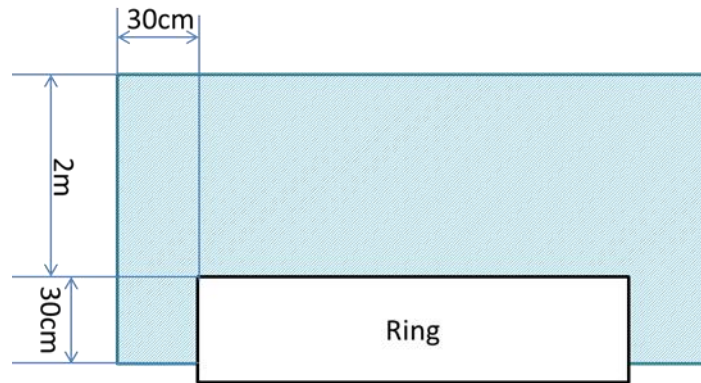

(1) Side view of the ring

Diagram 1 the size of rings

3.2 Outside disturbances

There are no specific regulations on the photographic equipment used by general spectators, media members or competition officials. For this reason, if there is a chance that a participating robot will be impacted by indoor lighting, sunlight, infrared light from cameras or video cameras, flashes or photographic lighting, etc., the participant is responsible for taking countermeasures.

4 Robot Standards

4.1 Method of movement

Robots must be bipeds capable of walking with steps that are 10 mm or higher. **However, must be able to identify feet, legs, arms, torso and head of the robot.**

Explanation 2

Walking is not screened in the standards screening, but if a referee judges during the competition that this standard has not been met, the competition will be interrupted and walking will be judged, so make sure your robot is able to walk right, left, forward and back taking steps that are 10 mm or higher.

4.2 Robot standards

The robot's shape is open as long as the following rules are observed.

4.2.1 Rules on feet and legs

- (a) The size of the soles of the feet (the part that comes into contact with the ground) is stipulated per weight category as shown in Table 1. The length of the sole from front to back must be X% or less of the length of the leg. **However, soles can be no longer than Y cm.** The width of the sole from right to left must be Z% or less of the length of the legs. Leg length is measured from the axis of forward and back movement at the very top of the leg to the sole of the foot when the leg is fully extended.

Table 1 Robot Sole by Weight



Robot Weight	X	Y	Z
1 kg or less (ROBO-ONE & Light & auto)	60%	12 cm	40%
2 kg or less (ROBO-ONE & auto)	55%	13 cm	35%
3 kg or less (ROBO-ONE & auto)	50%	14 cm	30%
5 kg or less (ROBO-ONE auto)	45%	16 cm	30%
7 kg or less	40%	18 cm	25%
10 kg or less	35%	20 cm	25%
Over 10 kg	30%	20 cm	20%

(Figures for weights over 3 kg are for reference.)

Explanation 3

As shown in Diagram 2, the leg length is the length from the axis of forward and back movement to the sole of the foot. The size of the foot is measured as shown in Diagram 3.

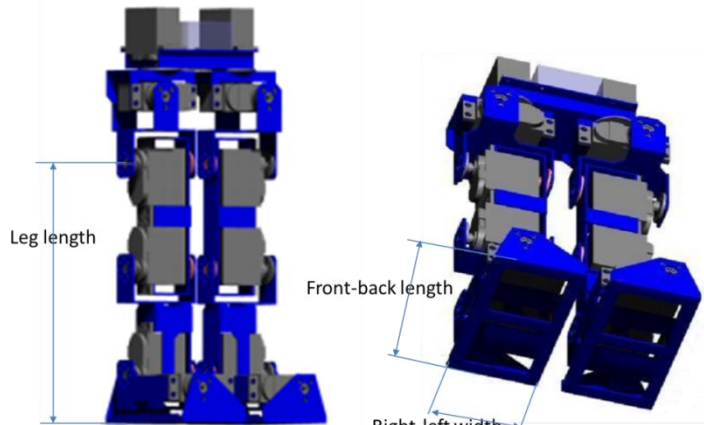

Diagram 2

Diagram 3

- (b) If in the shape of a clog (*geta*), the sole length is measured as the length of the red line in Diagram 4.

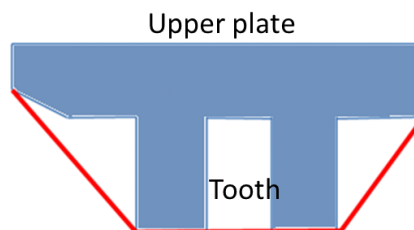

Diagram 4

- (c) When the robot is standing, the lines tracing the outermost perimeter of the soles of the left and right feet must not overlap when looked at from above.

Explanation 4

In the structure shown in Diagram 5, the lines tracing the outermost perimeter of the soles overlap, so the robot would not be allowed to participate. (The dark blue portion is the area that would be judged to overlap.)

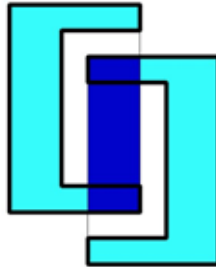

Diagram 5

- (d) Suction/absorption devices (including adhesive materials) must not be placed on foot soles.

4.2.2 Arms, tails, etc.

- (a) The length of parts that move away from the trunk must be Z cm or less, as shown in Table 2 by robot weight (see Diagram 6). For parts that move away from the robot trunk, excluding the legs, such as the arms, tail, neck, etc., the maximum distance from an arbitrary fixed position on the center line in the left-right direction as seen from the top of the robot must be within 120% of the length of the leg. The center in the left-right direction is the center point between the left and right legs. (See Diagram 7).

Table 2 Standards by Weight for Parts that Move Away from the Trunk

Robot Weight	Z	Range of Movement
1 kg or less (ROBO-ONE & Light & auto)	20 cm	Within 120% of leg length
2 kg or less (ROBO-ONE & auto)	25 cm	
3 kg or less (ROBO-ONE & auto)	30 cm	
5 kg or less (ROBO-ONE auto)	35 cm	
7 kg or less	40 cm	
10 kg or less	45 cm	
Over 10 kg	50 cm	

(Figures for the 5 kg or less category to the over 10 kg category are for reference.)

Explanation 5

For parts that move away from the trunk, the length of the portion that moves away from the trunk when fully extended is measured, as shown in Diagram 6. Even if the robot is covered with a stuffed toy, etc., the structure is checked and parts judged by the judges to move are measured.

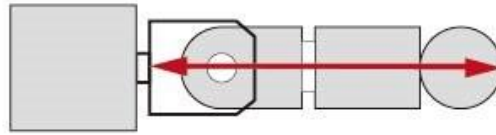
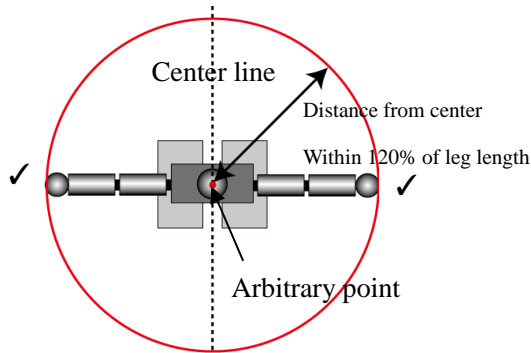

Diagram 6

Range of motion is measured as shown in Diagram 7 (robot seen from above).

Arms



Distance from arbitrary point on center line within 120% of leg length

Tails and horns

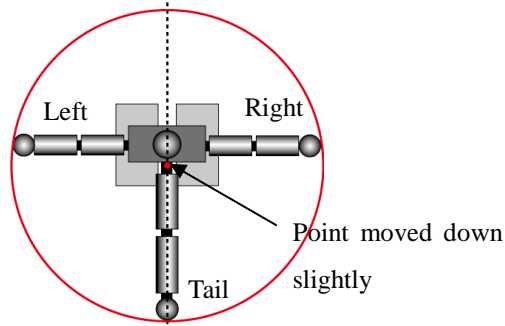

Point can be anywhere on center line, but...

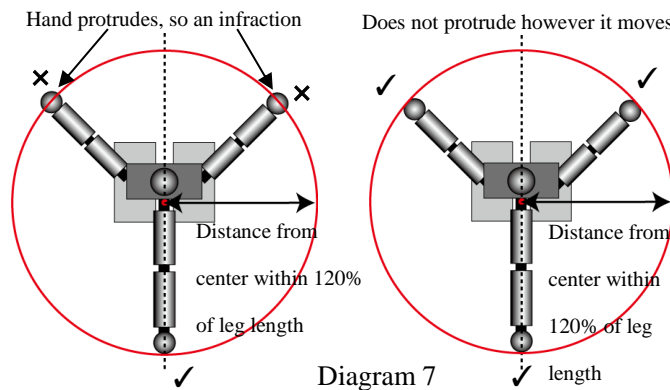

✓ : OK
× : Disallowed

Diagram 7

4.2.3 Center of gravity rules

- (a) The robot's center of gravity in the vertical direction must be clearly higher than the axis of forward and back movement at the very top of the legs. Also, when measuring center of gravity, parts like hands used for attacks must be placed below the axis for moving them away from the trunk. Center of gravity is measured using the seesaw method.

Explanation 6

Center of gravity is measured with the legs fully extended and the hands placed lower than when horizontally extended (see Diagram 8). Program the robot so that it can get into a position that allows its center of gravity to be measured (see Diagram 9).

With this type of robot

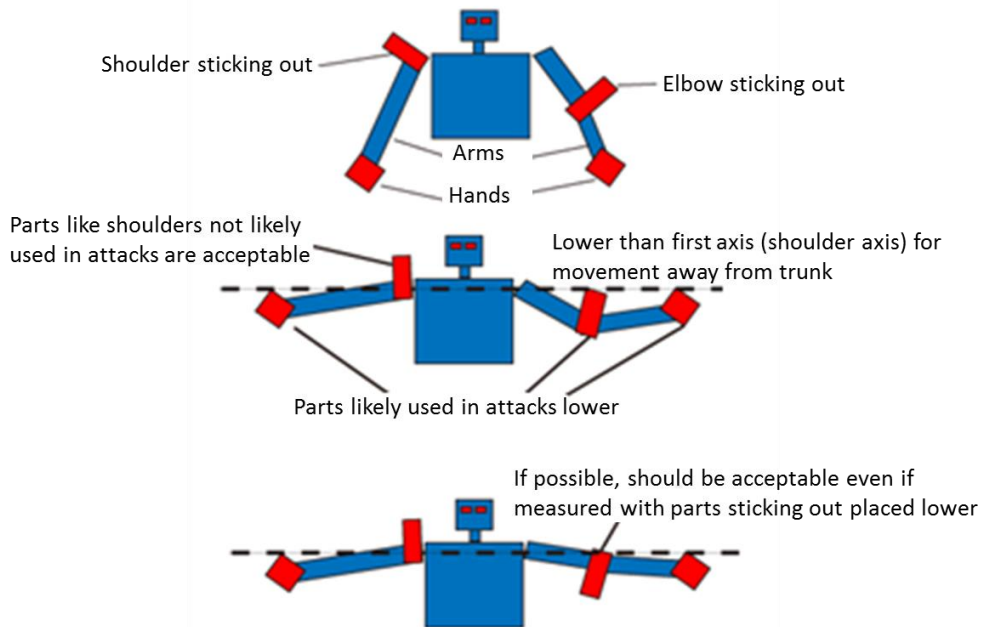
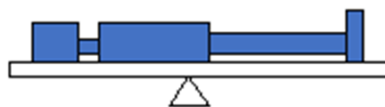

Diagram 8



Seesaw Method

Diagram 9

4.2.4 Prohibitions

- (a) The power source must be mounted inside the robot.

Explanation 7

If the battery is exposed on the outside, there is a risk of shorts or fire, so position the battery to prevent shorts and battery damage in normal matches between robots made of metal and plastic, etc. Also, adequately protect circuit boards and power-supply lines.

If judged to be in a dangerous position, a red card (1 “down”) is assessed, and if it is not



repaired within 2 minutes, a technical knockout is assessed. If there is smoke or fire, a technical knockout is immediately assessed.

For example, if the battery cover comes off during the match and exposes the battery, the referee judges that there is risk involved and orders it repaired. This count as 1 “down,” and the repair time is 2 minutes, the same as timeout rules.

At this time the participant is not allowed to increase the weight or change the position of the center of gravity. Repairs could include screwing the cover down or taping it down with plastic tape, etc.

(b) Parts that could hurt someone are not allowed.

Explanation 8

The judge checks in the standards screening by directly touching the parts, and if judged to be a danger, the participant is asked to make repairs. If repairs cannot be made, the robot is disqualified. Make sure to conduct adequate processes such as deburring.

- (c) Robots must not have jamming devices or other devices that intentionally disrupt the opponent’s control such as lasers or strobes. **However, sensing equipment such as laser range sensor is excluded.**
- (d) Robots must not use any parts that could damage or dirty the ring.
- (e) Robots must not have objects, liquids, powders or liquids that can be blown at the opponent.
- (f) Robots must not have devices that ignite.
- (g) Robots must not have weapons that could damage the opponent or ring. Dangerous objects like knives or things that revolve at high speeds are prohibited.
- (h) Robots are not allowed to fly or move using fans or propellers, etc. that revolve at high speeds.
- (i) In addition to the above, if a judge or referee judges something to be antithetical to the spirit of ROBO-ONE, it is ruled non-compliant.
- (j) Robots are not allowed to have structures that hook other things or have hands, arms or tails that hold highly adhesive materials, hooks among others.

Explanation 9

When a robot grabs and knocks down its opponent using a hooking structure or with hands made with a highly adhesive material, the attack is not valid. However, this does not mean



that grabbing, pinching or hugging actions, etc. are disallowed.

4.3 Shape may not be altered

Robots must not be modified to alter their shape at any time during the preliminaries and finals.

4.4 Replicas not allowed

Robots that replicate the shapes or forms of existing characters or people not authorized by the ROBO-ONE committee, as well as use of their illustrations or photos, etc., are prohibited. Copyrighted music and voices, trademarked names and other equivalent items also must not be used.

When necessary, permission must be obtained by the participant.

5 Robot Control

5.1 Prelims/Finals Control Method

During the prelims and finals, robots may be self-controlled by a computer or controlled manually by a human operator. If controlled manually, wireless communications must be used (radio, infrared, etc.). Participants must consider match conditions (light, sound, radio waves) and take steps to keep from obstructing control by the opponent even if using the same system. If using low-power, weak-signal radio control, use a wireless system with eight or more frequency channels. Also, if using an RC proportional controller, have at least eight crystal oscillators available.

Explanation 10

RC controllers should use the following frequencies.

27 MHz band: 26.975-27.255 MHz (12 bands, 1 to 12)

40 MHz band: 40.61-40.75 MHz (8 bands, 61, 63, 65, 67, 69, 71, 73, 75)

AD band (25 MHz weak, 20 bands)

2.4 GHz band, 5 GHz band

Approved wireless LAN, Bluetooth, ZigBee, etc. may also be used.

Use of wireless formats not approved in the host country is prohibited.

You should use systems that allow eight channels to be used simultaneously.

Preparations may be performed by friends or a team. After participants in the finals tournament are determined, wireless frequencies are assigned to the robots. If using a remote controller, have the crystal oscillators available up to this time.



5.1-2. ROBO-ONE auto's robot operation method

The robot must be an autonomous motion by a computer and a sensor installed in the robot during the game. However, the robot is connected to the network and the robot can exchange information without human operation.

~~The robot is designed to start its motion at the beginning signal of the referee and to stop the motion with a stop signal, and at this time human manipulation is permitted.~~

The robot is designed to start its motion at the beginning signal of the referee and to stop the motion with a wait or a stop signal, and at this time human manipulation is permitted.

6 Prelims Format

- (a) Each robot travels 4.5 meters. (This may change depending on the venue and operational circumstances.) The time limit is 1 minute. If the robot has not reached the goal after 1 minute, the distance from the start to the point reached after 1 minute is recorded. The width of the lane is 90 cm. If the robot goes out of the lane, the distance from the start to that point is recorded. Places are determined by the time to the goal or distance achieved.
- (b) Travelling in the direction of the goal must be accomplished by walking only—the left and right foot alternate in being put forward. The feet do not need to alternate if making adjustments to stay in the lane or change the robot's direction, etc.
- (c) Robots must not move toward the goal when anything other than its feet soles are touching the ground.
- (d) If the robot falls over, it gets up at that spot and continues the competition.
- (e) The lane uses the ROBO-ONE ring, but a part of the course may have a sheet with a thickness of 5 mm or less placed down on it and affixed with double-sided tape. Two types of sheet material are used, one with good grip and one that is slippery. (Changes may be made depending on the circumstances at the venue.)
- (f) The order in the prelims is determined randomly and the robots race in the predetermined order. A 10-second penalty is assessed each time a participant passes their place in the order. If a robot is unable to complete the race, 50 cm is subtracted from the measured distance travelled.

Explanation 11

In future competitions, there will be bumps of 10 mm or more, or a target will be set up midway that has to be punched, etc. in order to promote higher levels of walking and attack abilities.

7 Finals Tournament

- (a) Matches are generally 1 round of 3 minutes and are won by knockout or number of “downs.” Depending on the number of participants and other circumstances, the match



time may be changed.

Explanation 12

A 1 point difference in the number of yellow cards cannot determine a victory. Only the difference in the number of downs (including two yellow cards) determines which robot won. However, this does not apply to overtime.

- (b) When neither robot secures a victory in one round, there is a 2-minute overtime round that is decided by sudden death—whichever robot scores a down first wins. If there is no winner even after overtime, victory is determined by the judges on points. However, if it is the final contest, depending on the situation, there may be another overtime. Also, when there are large numbers of participants, victory may be determined by decision without conducting overtime.

Explanation 13

The number of “slip-downs,” the number of attacks, yellow cards in the match, etc. during overtime are tabulated in the final point total.

- (c) The preparation time until the match starts is less than 2 minutes, and a red card is assessed if this is exceeded. A red card is treated as 1 down. After that, yellow cards are given each minute, with two yellow cards becoming a red card. .

Explanation 14

The match order is listed on the tournament schedule, so be ready at your match venue by the start of the match three matches prior to yours. After you are called, the match proceeds in accordance with the above competition rules.

The tournament schedule is updated in real time, so check it to confirm the progress of the matches.

- (d) The ring has a red corner and a blue corner; the left side of the tournament schedule is red and the right side is blue. When the schedule is written vertically, the upper is red and the lower is blue.
- (e) There are rules on where participants may stand during the competition to allow spectators to enjoy the technological brilliance and entertainment value of the robots and to record the proceedings for video distribution. During finals matches (not including timeouts) and the prelims, participants must not enter the ring or touch the robots. Touching a robot results in a yellow card.

Explanation 15

Participants are everyone around the ring, including the people operating or controlling the robots, people participating in teams and other supporters, etc. **People other than those controlling the robots may not stand.**

Instructions will be provided on the day of the event regarding the ring and standing area for competition participants in this tournament.

8 Match Rules

8.1 Walking

- (a) If instructed by the referee, the robot must lift the soles of its feet at least 10 mm off the ground and proceed forward, backward, left and right for at least three steps.
- (b) Robots are not allowed to walk in a crouching position, and the judgment on this is made by the referee and judges.

Explanation 16

Walking in a crouching position refers to when the knee joints are at 90 degrees or less, or when crouching with the hip joints open 90 degrees or more left to right. The same applies when two servos are used for the knee joint (see Diagram 10).

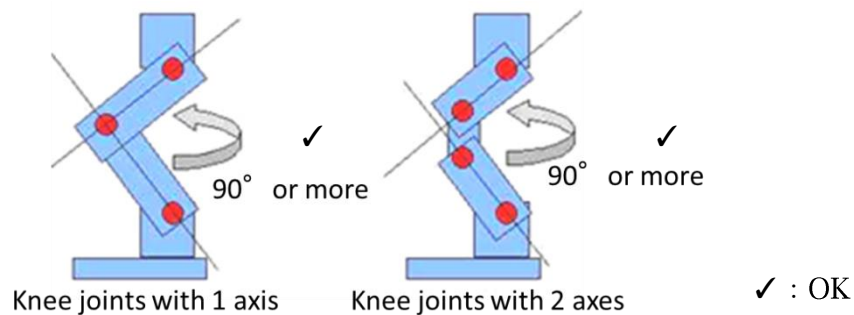

8.2 Match Proceedings

- (a) Robots may attack after the “fight” indication is given by the referee.
- (b) If the opponent goes down, the other robot must back away 1 m or more from the opponent.
- (c) When a robot goes down and does not get up after the referee counts to ten, it is a knockout (K.O.), and the other robot is awarded the victory. The count will continue even if the round has ended.
- (d) When a robot is knocked down three times during the same match, it is ruled a knockout and victory is awarded to the opponent.
- (e) The match continues even if both robots fall on top of each other due to an attack. However, if the referee judges that it is not possible to continue the match, the robots are placed in the fallen position apart from each other and the count is commenced.

Explanation 17

Make it possible for your robot to depower at the reference’s signal if the two robots



become entangled. Build your robot so that the power can be turned off quickly and it can be restarted quickly.

Also, in order to ensure the referee's safety, do not operate your robot without the referee's signal. The penalty is a yellow card.

- (f) Do not attack a robot when it has gone down.
- (g) If a robot has stopped without falling down for 3 seconds or more, it is ruled a "standing down," and the count begins. When the robot moves, it is regarded as having recovered from the "down."
- (h) "Give up" may be indicated to the referee during the match. If the referee then judges that the match cannot be continued, a "technical knockout" may be declared.
- (i) If a robot crouches to attack or defend, etc., it must stand back up within 3 seconds. The robot then may not attack or crouch again until it has taken at least three steps. If there is a violation, a yellow card will be issued by the referee.

Explanation 18

Walking in a crouching position refers to when the knee joints are 90 degrees or less, or when crouching with the hip joints open 90 degrees or more left to right. This same applies when two servos are used for the knee joint (see Diagram 10).

See Diagram 10 in Explanation 16.

- (j) If the match rules are broken or there is unsportsmanlike conduct, a yellow card or red card may be issued on the referee's judgment.
- (k) If a part falls off (not including screws), a yellow card is assessed. If the situation is judged to be dangerous, a red card is assessed and the participant is ordered to make repairs.
- (l) Time does not stop unless there is indication from the referee.

8.3 Rules on Downs

- (a) A robot is ruled "down" only if it falls due to a valid attack.

Explanation 19

Attacks should be effective punches or moves that involve grabbing and throwing the opponent.

- (b) If the robot goes out of the ring, it is treated as equivalent to one down.
- (c) If the robot goes out of the ring when standing up after going down due to a valid attack, it does not count as an additional down. If both robots go out of the ring at the same time as an attack, the robot that made the valid attack is not considered down.



- (d) Two yellow cards become a red card, which is treated as equivalent to one down.
- (e) If a robot is slipping frequently during the match, the referee may stop the match, conduct a walking test (make the robot walk forward, back, left and right), and if the robot cannot walk in a stable manner, the referee may declare a technical knockout.
- (f) If the referee judges that a robot has repeatedly slipped intentionally (including falls that do not result in a down or diving in response to an attack, etc.), a yellow card is assessed.
- (g) If the robot is fully automated except for the start/stop button, its opponent is given one down as soon as the match starts.

8.4 Taking timeouts

- (a) Participants may request that the referee call “time” (a timeout) once per match.
- (b) The referee receives the request, judges the situation in the match and calls the timeout.
- (c) Timeouts must be no longer than 2 minutes.
- (d) When the timeout is called, it is treated as one down.
- (e) The timeout is not recognized if your robot has received a valid attack and gone down.

8.5 Attack rules

8.5.1 Crouching attacks

- (a) Crouching attacks are prohibited.

Explanation 20

“Crouching attack” refers to attacks made in a crouching position, the same as walking in a crouch in Explanation 16.

8.5.2 Lateral attacks

- (a) Lateral attacks are prohibited.

Explanation 21

“Lateral attack” refers to attacks made at ± 45 degrees in the lateral direction from your robot. Lateral direction is the direction at a right angle from the direction the robot is walking; **The walking of the robot must be same as the walking specified by prelims.**

The intention to attack in the walking direction includes not only the upper body but the movement of the legs as well. So, the direction the legs are facing is forward.

Even if the opponent's robot is not next to your robot, the Lateral attack may be judged to be an attack for checking.

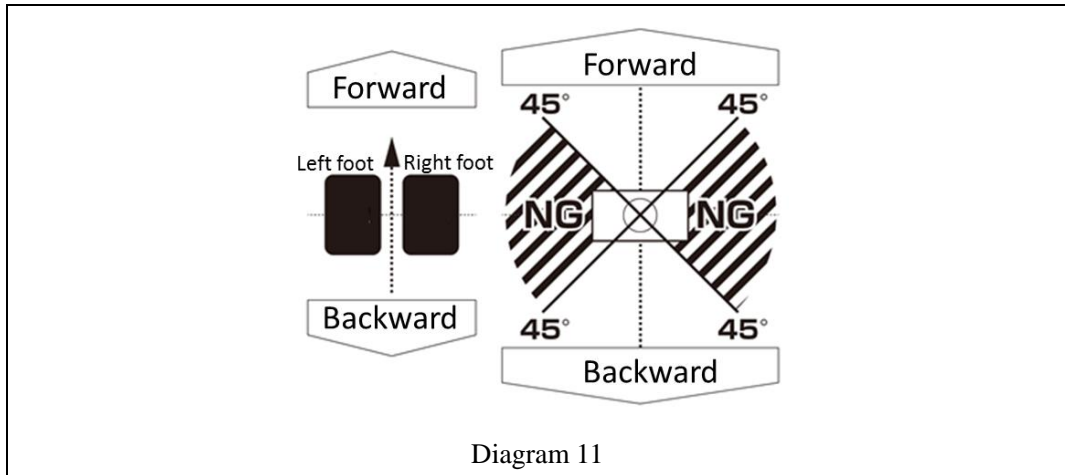

8.5.3 Sacrifice attacks

- (a) Attack moves in which a part of the robot other than the feet touch the ring just before or after attacking the opponent are called “sacrifice attacks,” and regardless of whether the opponent goes down, each of the three types of sacrifice attacks can only be conducted once per match, including overtime.

Explanation 22

Attacks involving falling onto the opponent, frontwards somersaults or head-butts with both hands and feet on the ring, etc. are regarded as sacrifice attacks.

If parts other than the feet touch the ring, it is counted as a “down,” but slipping down intentionally is a yellow card. When attacking from below, a hand touching the ring, etc. is regarded as intentional. Be aware though that it may also be regarded as a sacrifice attacks.

Attack is effective by placing the center of gravity on the opponent. At this time, when the robot is not controlled and falls down, it is judged Sacrifice attack.

Also, when the robot grasps the opponent by hand and falls together, it is regarded as a Sacrifice attack.

8.5.4 Owaza (“bold attack”)

- (a) Attacks involving holding and throwing the opponent are “**throws.**” “Throw” decisions are made by the referee. Attacks that result in the opponent coming off the ring into the air are called “owaza,” or “bold attacks.” Owaza can be worth 2 downs. Owaza decisions are made by the referee, but they require the consent of a majority of judges. Lateral attack rules do not apply to owaza.
- (b) Generally, owaza is rewarded when the opponent is knocked over with a kick that is higher than the position of your robot’s waist. If it is not a valid attack and your robot loses its balance and something other than the feet touch the ring, it is regarded as a sacrifice attack.



Explanation 23

If a throw or owaza is executed and the attack is valid, it is not regarded as a sacrifice throw even if parts other than the feet touch the ring before or after the attack. However, if invalid owaza continue, a yellow card may be issued by the referee.

Owaza that send the opponent into the air off the ring are specifically defined as follows with the names commonly used in martial arts. However, they are not limited to these moves; the decision of the referee and judges is given precedence.

*Owaza are still not clearly defined and are left up to the judgment of the referee and judges. In the case of a new owaza, or if the referee cannot make a clear decision, the decision is made by the referee and judges. You should consider the risk that a move may not be recognized as owaza before taking up the challenge.

- Back-drop
- Shoulder throw
- Leg sweep
- Overhead throw
- High kick